

## NESTING 101

### Question:

Are the nests below good examples of PLATE UTILIZATION and PRODUCTIVITY?

### Answer:

**ABSOLUTELY NOT!**

Can your machine cut the nests below? Yes, but are you sure you want to? At first glance, busy nests may *look* impressive, but in most cases the plate utilization is an illusion and the productivity is not what it could be.

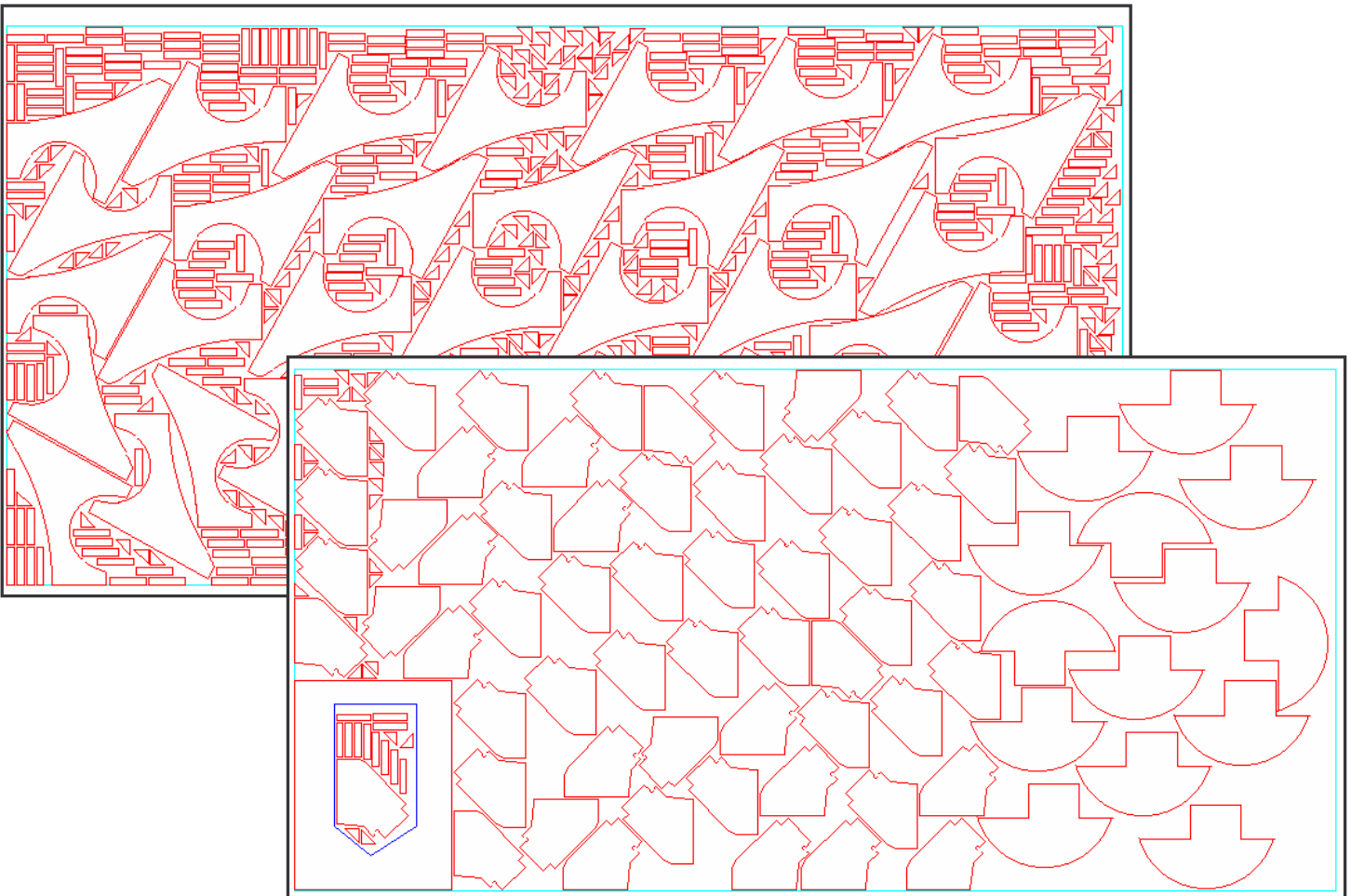

These nests are accurate examples of how other nesting software products nest parts. Their approach will start out like P.E.P. and then become an inefficient mess no production manager should want to cut. The nesting examples on the following pages will explain and compare P.E.P.'s Approach vs. "The Other Approach".

# P.E.P. Advanced True Shape Nesting vs. Other Products.

Our goal in producing this document is to educate people about the relationship between POWERFUL nesting software and the productivity of cutting machines.

We say "educate" because most people have never seen a finished cutter path or a packed nest generated the way P.E.P. does it. P.E.P. frequently nests **10% to 20% more parts than our closest competitor, eliminates 95% of all head raises, shortens the rapid distance between parts, etc. etc.**

But don't take our word for it. After you have reviewed the nests on the attached sheets, *put your software to the test.* Please call MMI and we will download the necessary DXF files for you to analyze the nesting capabilities of your current nesting software.

## Advanced True Shape Nesting!

Only P.E.P. has the Advanced True Shape Nesting Technology. The nests on the following pages will prove this and demonstrate how the Advanced True Shape Nesting logic will substantially:

- Increase your production output
- Increase your plate utilization
- Improve part quality
- Lower production costs

## How Can P.E.P. Do It AUTOMATICALLY?

P.E.P. uses these and other proprietary mathematical algorithms to generate its nests.

FEATURE	PAGE
• Double Interlocking Pairs	3-5
• Primary and Secondary Pair Logic	7
• Fill Area Logic	8-9
• Super Squeeze Logic	10-12
• Combine cutting logic	13-15
• Ring logic	
• CPT, sequence and lead-in logic that eliminates head raises	
• Radiusing of line line, line arc and arc arc geometry to increase cutting speeds.	

So, lets get started, please turn the page.

# Double Interlocking Pairs in X & Y

## 38 vs. 50 Parts Per Sheet

This is one of the parts shown on the front cover of this document. The **P.E.P. Automatic Nesting software** nested **fifty** parts on the sheet. When you remove the filler parts used to disguise the poor nesting logic you get the real story.

P.E.P. nested **fifty** parts, 12 more parts than the competition.

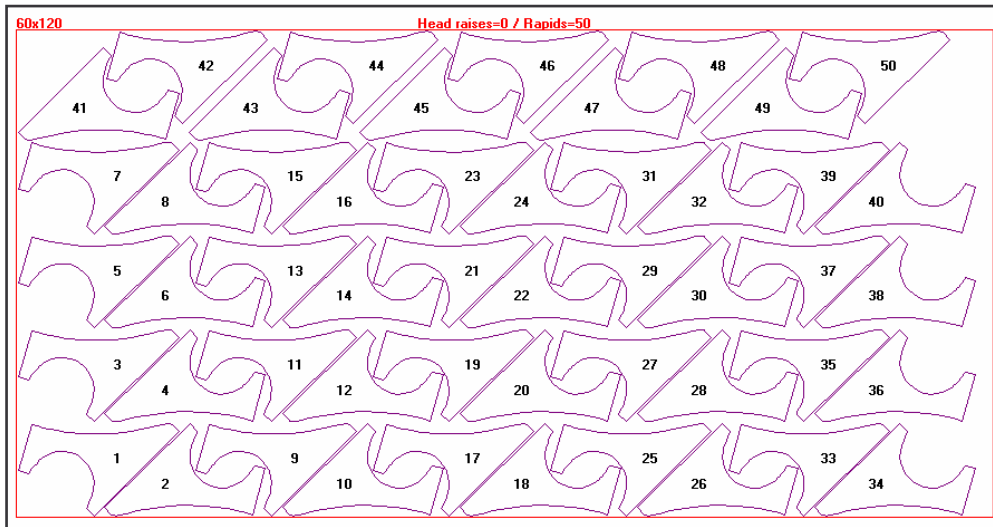

Without double interlock logic the competition doesn't come close. In this case, **only thirty-eight of the parts went down**, twelve parts did not fit on the sheet using their nesting algorithms. This nest is typical of the nesting logic used by other nesting products.

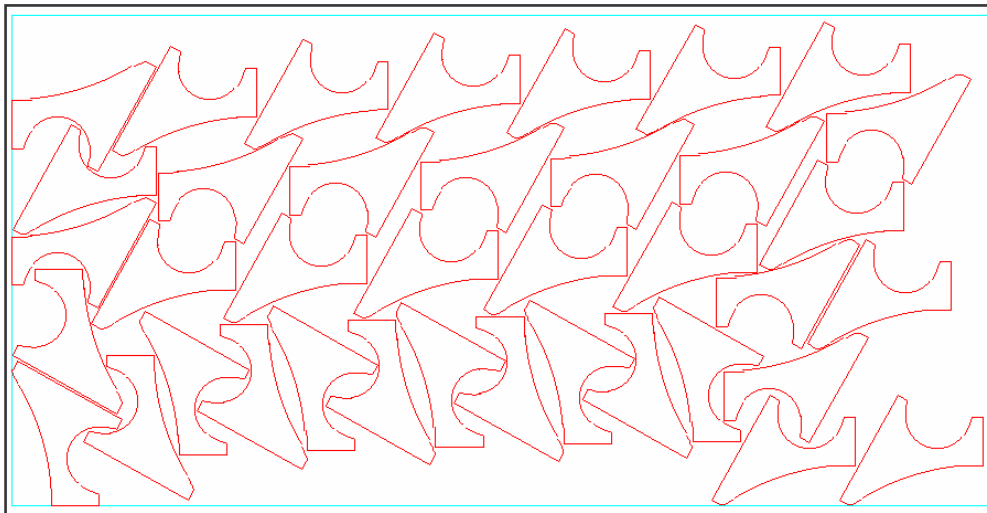

# Double Interlocks Pairs in X

## 77 vs. 84 Parts Per Sheet

In this example the **P.E.P. Automatic Nesting software** nested **eighty-four** parts using the double interlocking logic.

P.E.P. nested **eighty-four** parts.

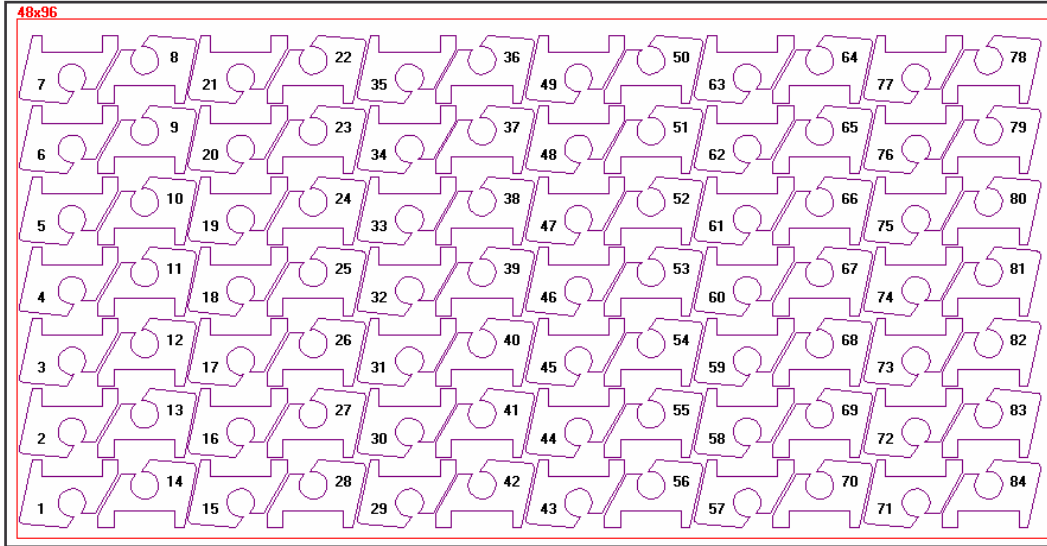

Without double interlock logic **only seventy-seven of the parts went down**, seven parts did not fit on the sheet.

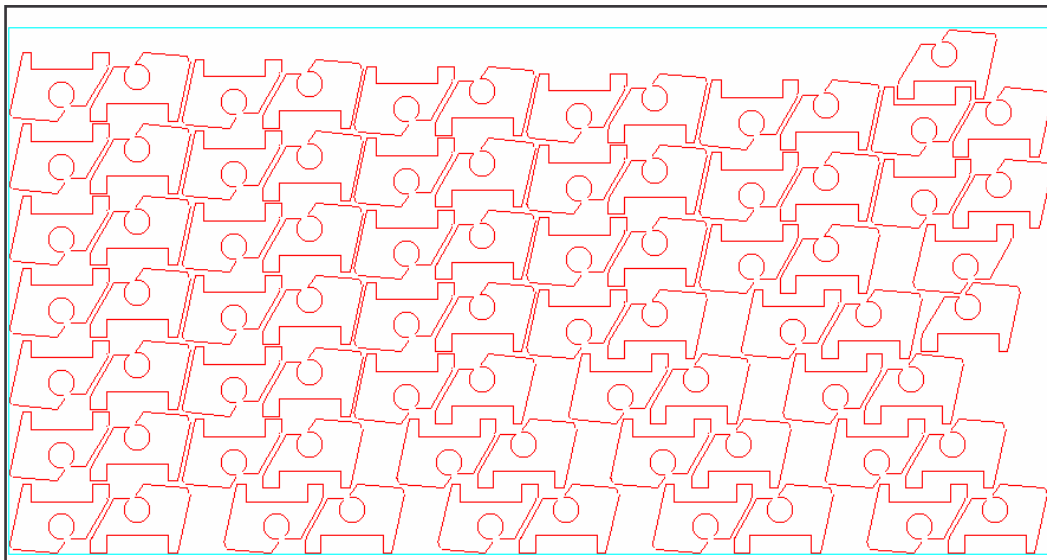

As you can see, P.E.P. will *always* put down more parts per sheet when nesting parts that can be interlocked. The following are a few more examples of the P.E.P. Interlocking logic.

# "Multiple Part" - Double Interlocking Parts

You might recognize the bottom nest from the front cover.

The top nest was generated by the **P.E.P. Automatic Nesting software** resulting in:

1. More parts go down on the sheet with P.E.P. - four of the mushroom parts to be exact.
2. The lead-in location will be assigned to the same geometry on identical parts within the column resulting in the parts being saved as sub-routine calls. This significantly reduces the file size of the posted code and the amount of memory required to cut the nest.
3. The organized columns and rows improve the chances of assigning the lead-in location so that the cutter path does not travel over previously cut parts when moving from one part to another, there-by eliminating head raises.
4. Inspecting parts is less of an issue also because most of the parts will be cut using the same cutter path saved as a post processed sub-routine.

This nest was created by P.E.P.

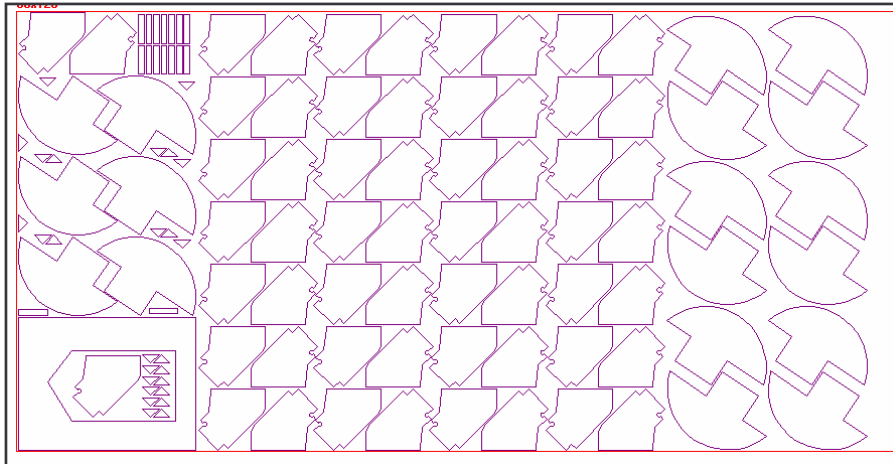

Once again the Other Approach doesn't come close. Not only does this nest come up short by four parts, imagine the file size, head raises and crash problems one might encounter cutting this nest!

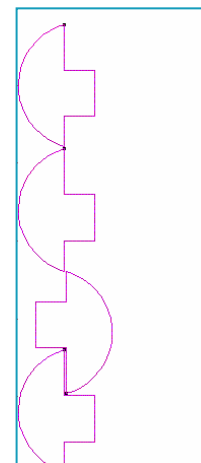
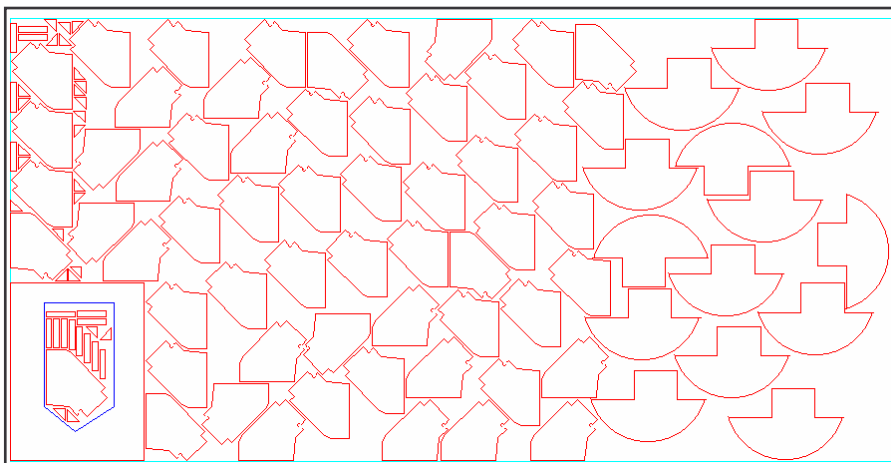

# Duplicate Plates vs. No Duplicates

The P.E.P. Automatic Nesting software analyzes the parts to be nested before it starts nesting so that the maximum number of duplicate plates can be generated. The Other Approach counts up the parts after each plate has been nested and then divides the nested quantities into the remaining quantities. As you can, the nest below on the right does not have duplicate plates.

**P.E.P = 3 Programs, 3 1/3 sheets**

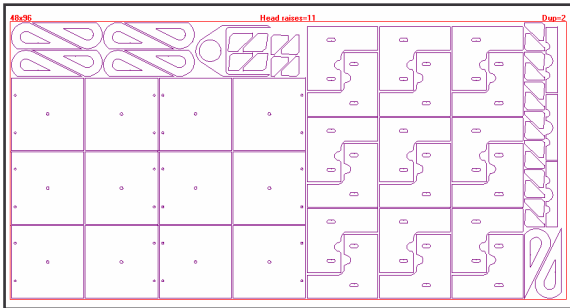

**Other Approach = 4 Programs, 3 1/2 sheets**

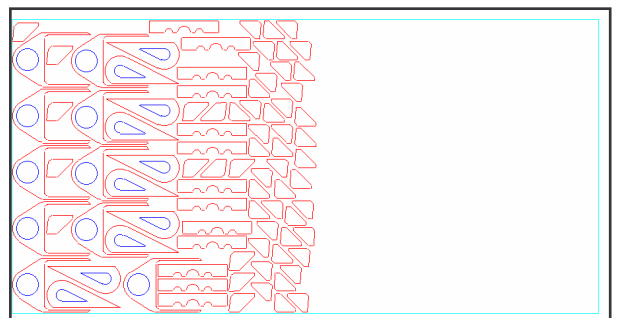
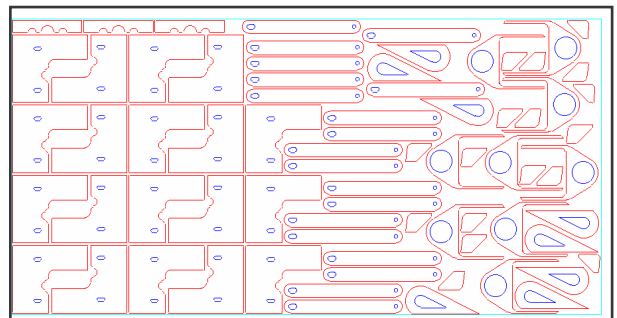
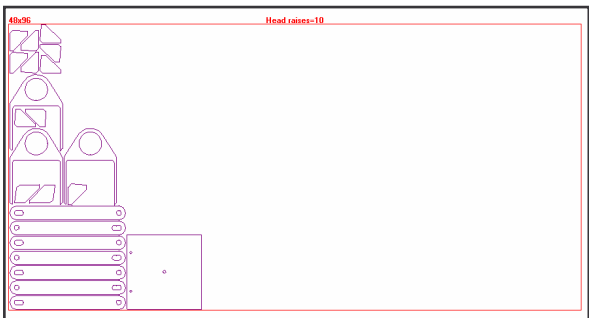
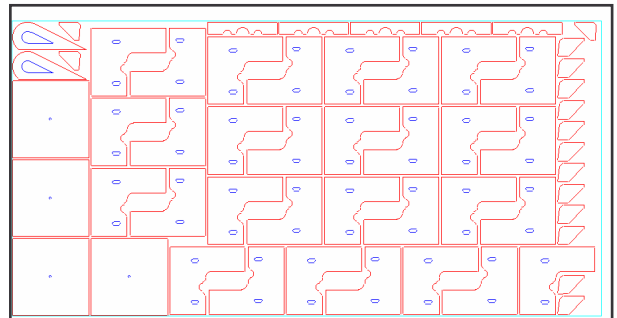
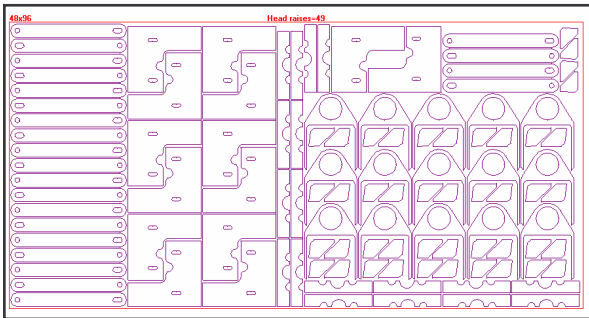
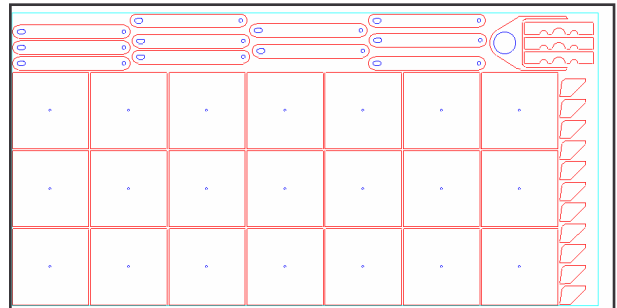

# Primary & Secondary Pair Logic

## 119 vs. 124 Parts Per Sheet

In the top nest the **P.E.P. Automatic Nesting software** nested **one hundred twenty-four** parts on the sheet. As always, the P.E.P. logic calculates the Primary and Secondary Pairs for all shapes. The logic will then determine the best method of nesting. In most nesting scenarios the primary pair will produce the greatest yield if the software is smart enough to find multiple rotations that will fill across the width and the length of the area to be nested, which in this scenario is the case. To further enhance the material yield, the logic will also nest secondary pairs to fill open areas of the sheet **as it did in the lower right**.

P.E.P. nested **one hundred twenty-four** parts.

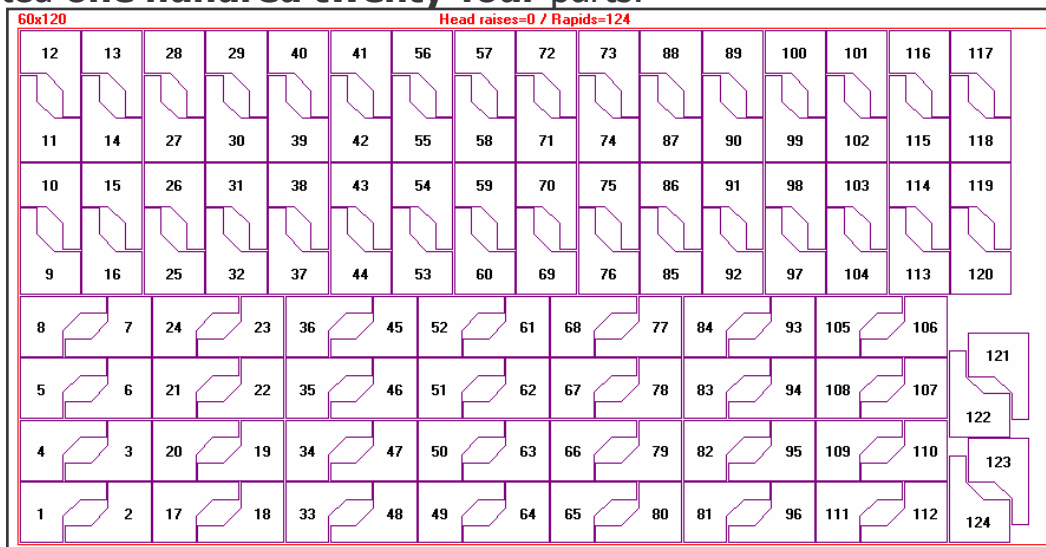

Using The Other Approach logic, without multiple rotations of the primary pair, **five** parts did not go down.

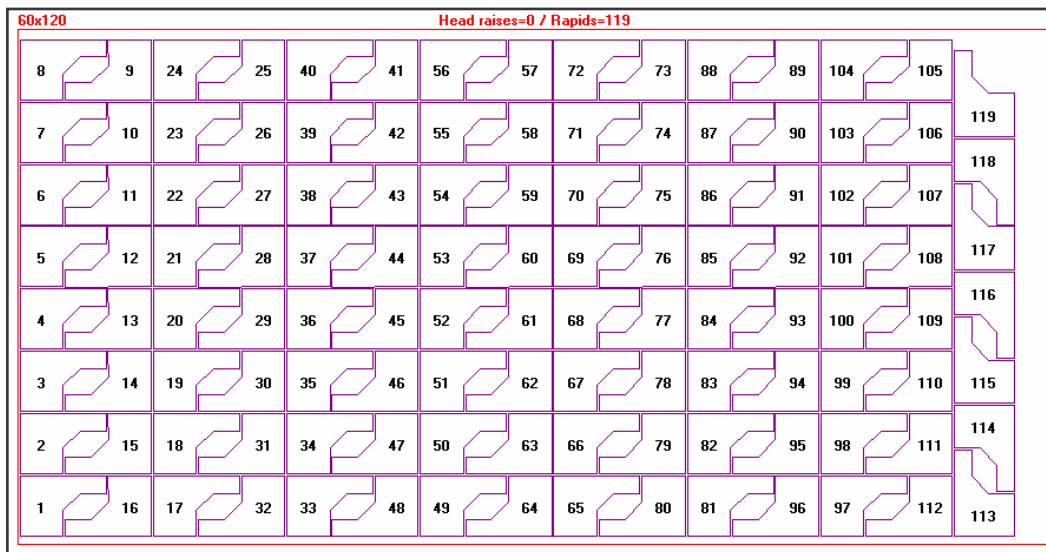

# Fill Area Logic

## 35 vs. 44 vs. 50 Parts per Sheet

The **P.E.P. Automatic Nesting software** will nest **fifty** of the parts below on a single sheet. The software uses logic called Fill Area. As can be seen below, the software puts parts together as pairs and then nests the pairs down at multiple rotations. The impressive part about this logic is that it knows when to pair parts, when to rotate and how to use multiple rotations to maximize the number of parts that will go down. The same logic works in columns and rows.

P.E.P. nested **fifty** parts

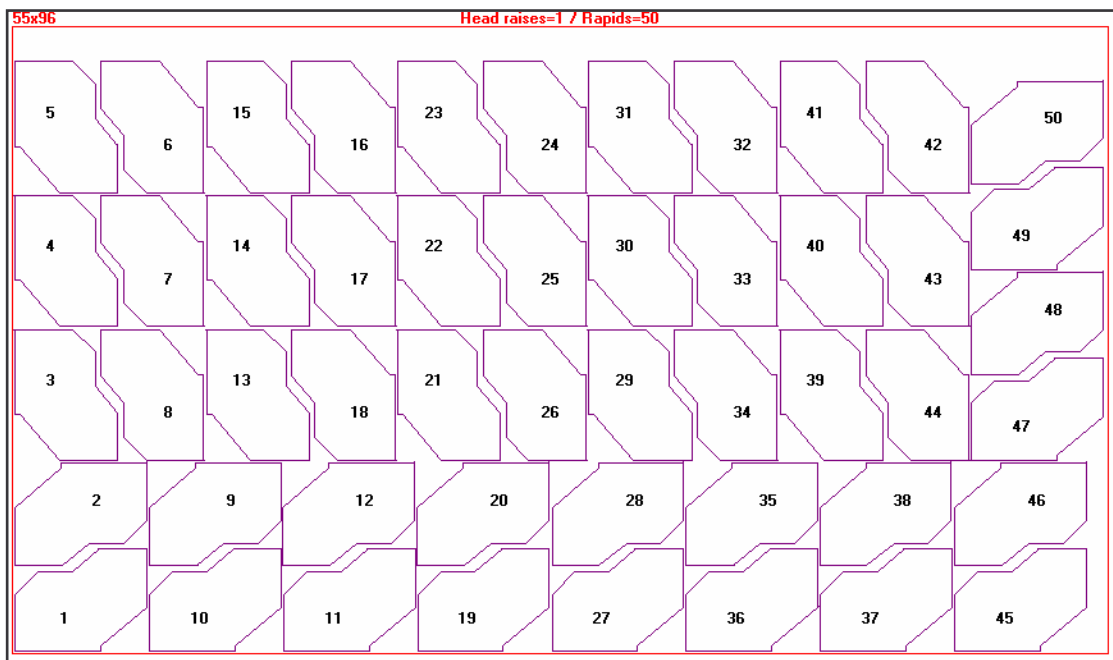

**Finished Part**

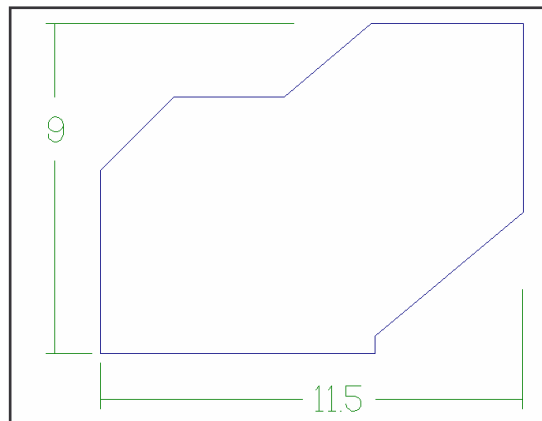

The nests on the next page illustrate the way The Other Approach attempts to nest this part.

# Fill Area Logic

---

## The Other Approach to Automatic Nesting

Below are three nests generated by the Other Approach to automatic nesting.

1. Single part column nesting – a total of 35 parts were nested, **15 parts** did not go down



2. Best orientation – a total of 43 parts were nested, **7 parts** did not go down

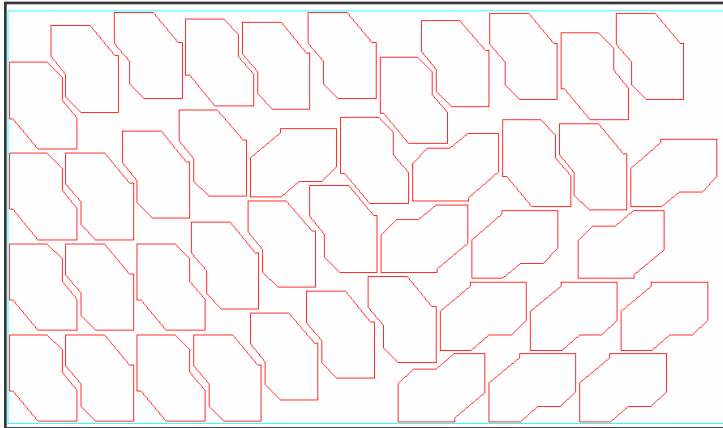

3. Column pair nesting– a total of 44 parts were nested, **6 parts** did not go down

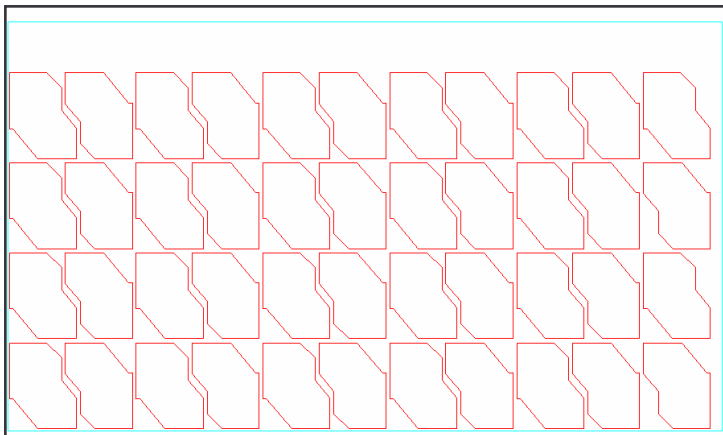

# Super Squeeze Logic

## 65 vs. 66 vs. 72 Parts Per Sheet

The **P.E.P. Automatic Nesting software** will nest **seventy-two** of the parts below on a 60 x 120 inch sheet. The software uses logic called super squeeze. As can be seen below, the logic is capable of spreading parts across the width of the plate to maximize the number of parts that will go down along the length of a sheet. The same logic works in columns and rows. Naturally, not all parts fit the super squeeze criteria, but most parts will!

P.E.P. nested **seventy-two** parts.

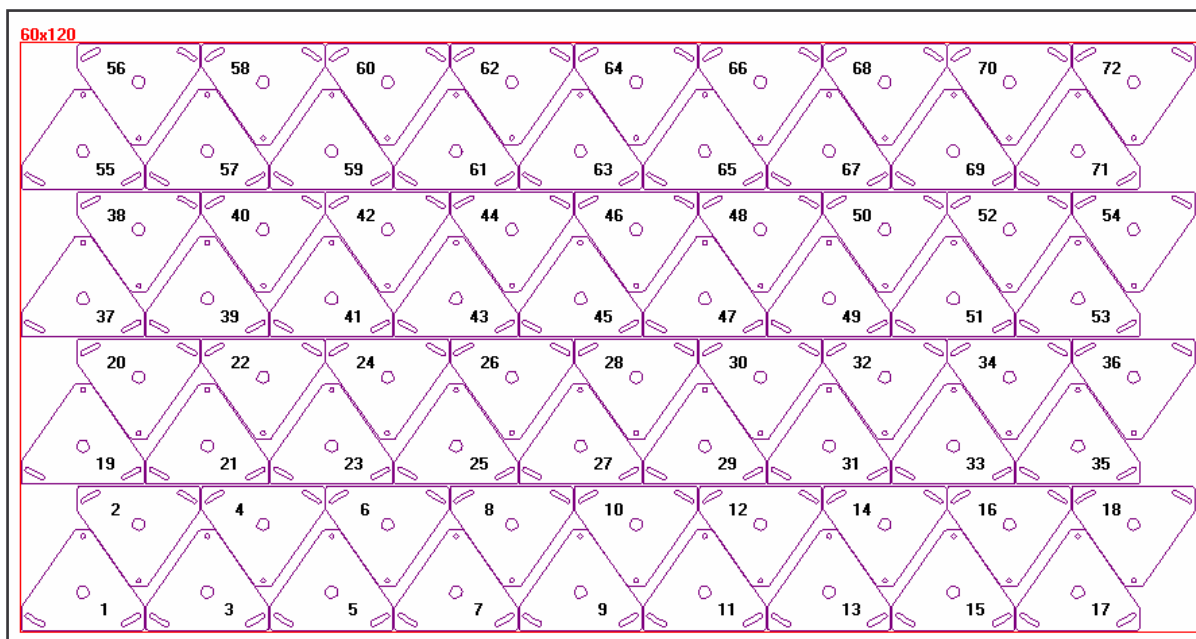

Finished part

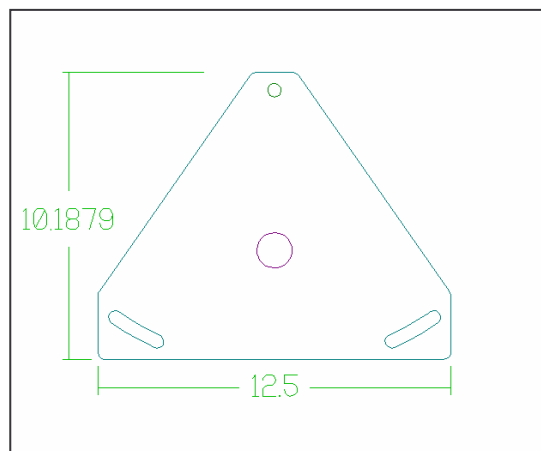

The nests on the next page illustrate the approach used by most other nesting software.

# P.E.P. Advanced True Shape Super Squeeze Logic

---

## The Other Approach to Automatic Nesting

Here are three examples of the same part nested by The Other Approach.

1. The Other Interlocking Approach - only 66 parts went down on this nest, six parts did not fit.

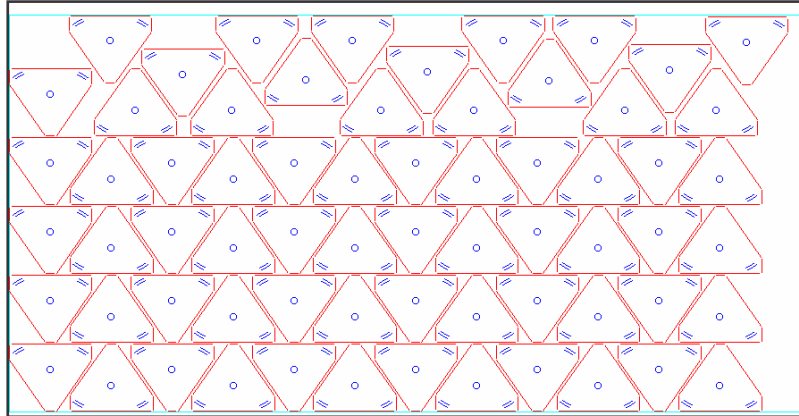

2. The Other Cluster Approach - only 65 parts went down on this nest, seven parts did not fit.

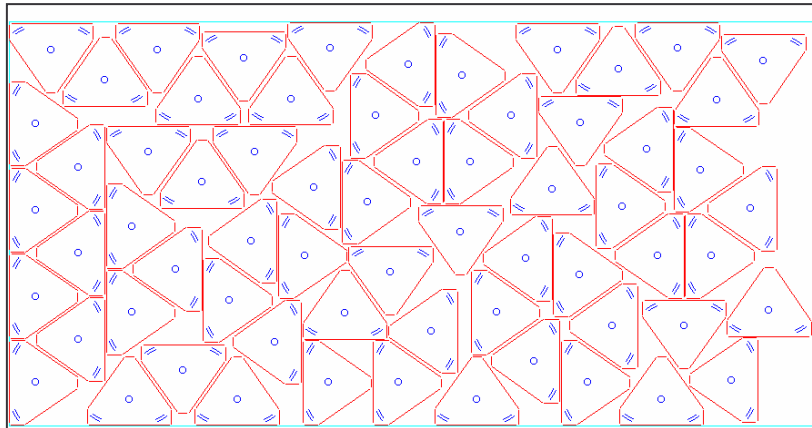

3. The Other Pairing Approach – only 65 parts went down on this nest, seven parts did not fit.

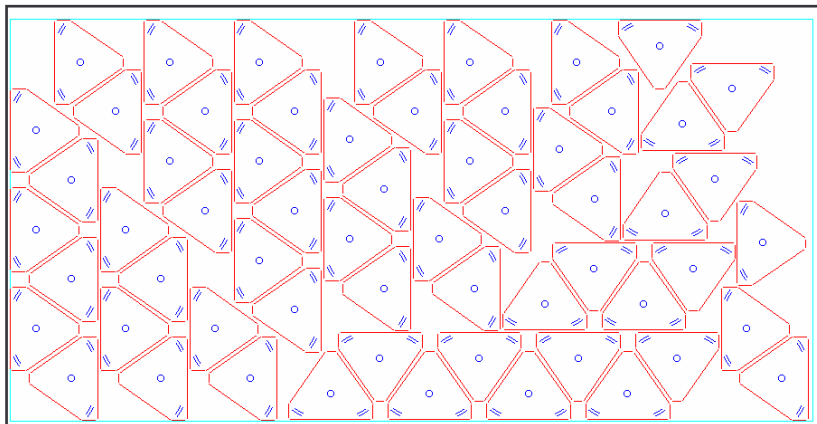

# Multi-Part Super Squeeze Logic

---

The following two examples demonstrate how the P.E.P. Super Squeeze logic is applied.

1. In this example Super Squeeze nested **two** of the smaller parts in the top right corner.

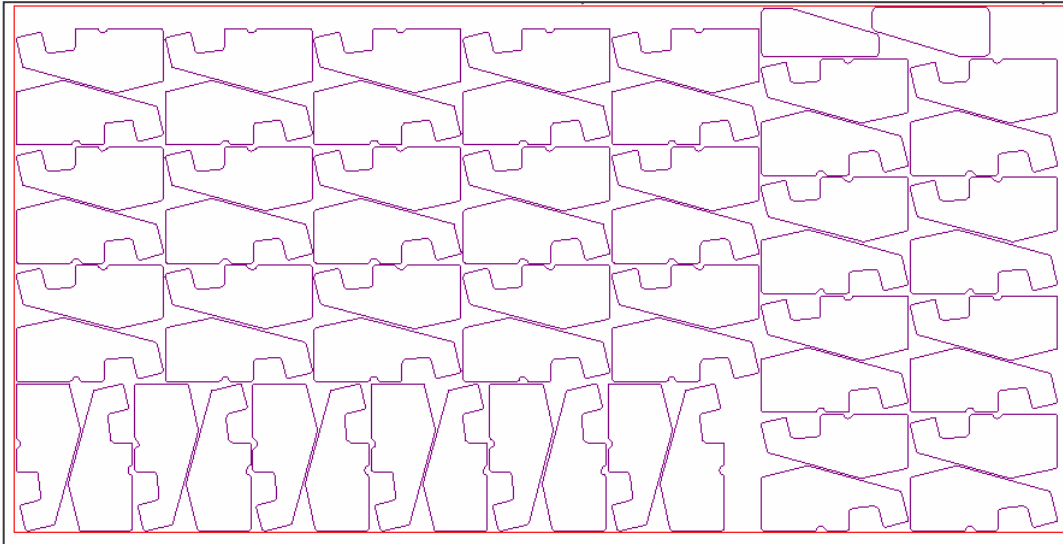

2. In this example P.E.P. Super Squeeze nested **five** of the smaller parts on the right of the sheet.

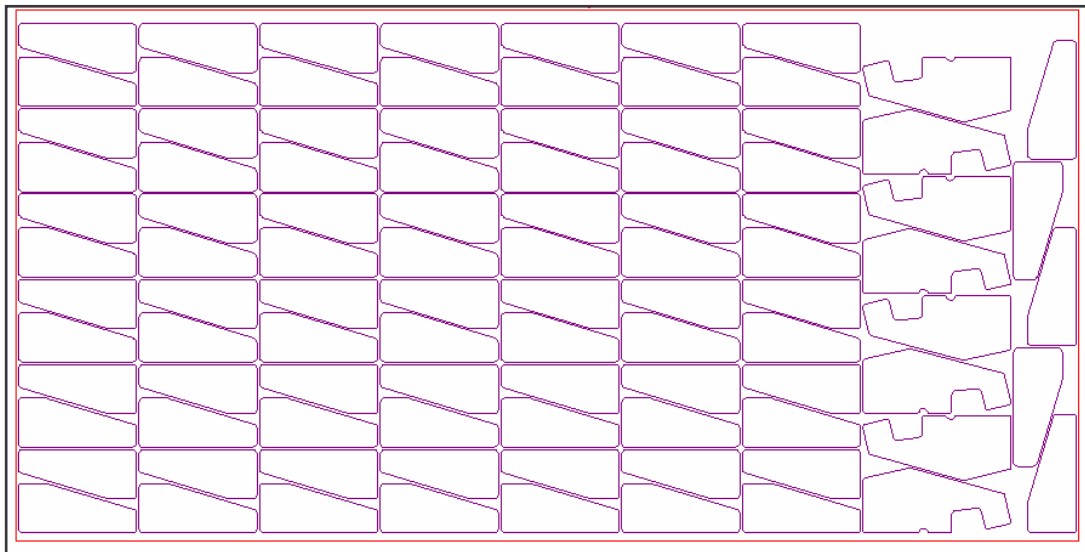

# Combine Cut Logic

## P.E.P. rotates parts to maximize Combine cutting.

The nest at the top of this page was created by the **P.E.P. Automatic Nesting software**. Every other part within the four columns is intentionally rotated so that multiple geometry on multiple parts can be common cut. We refer to the finished cutter path as combine cutting, no other software reduces the total cutting distance as significantly as this form of nesting.

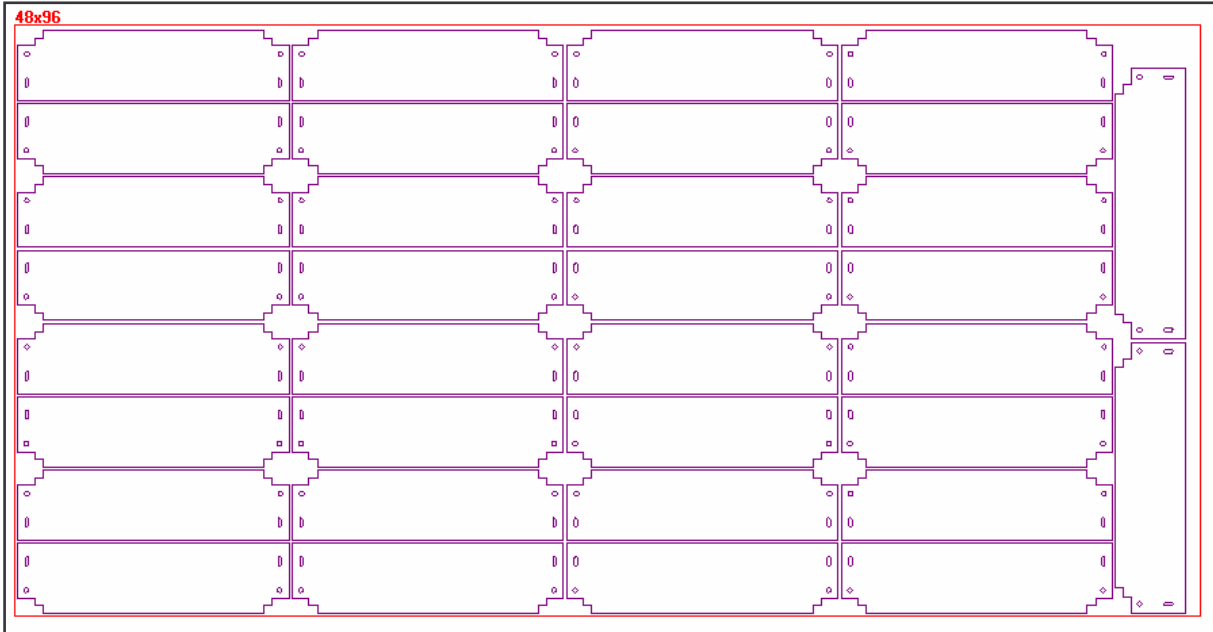

The nest below is typical of the logic used by The Other Approach - **two** parts did not go down.

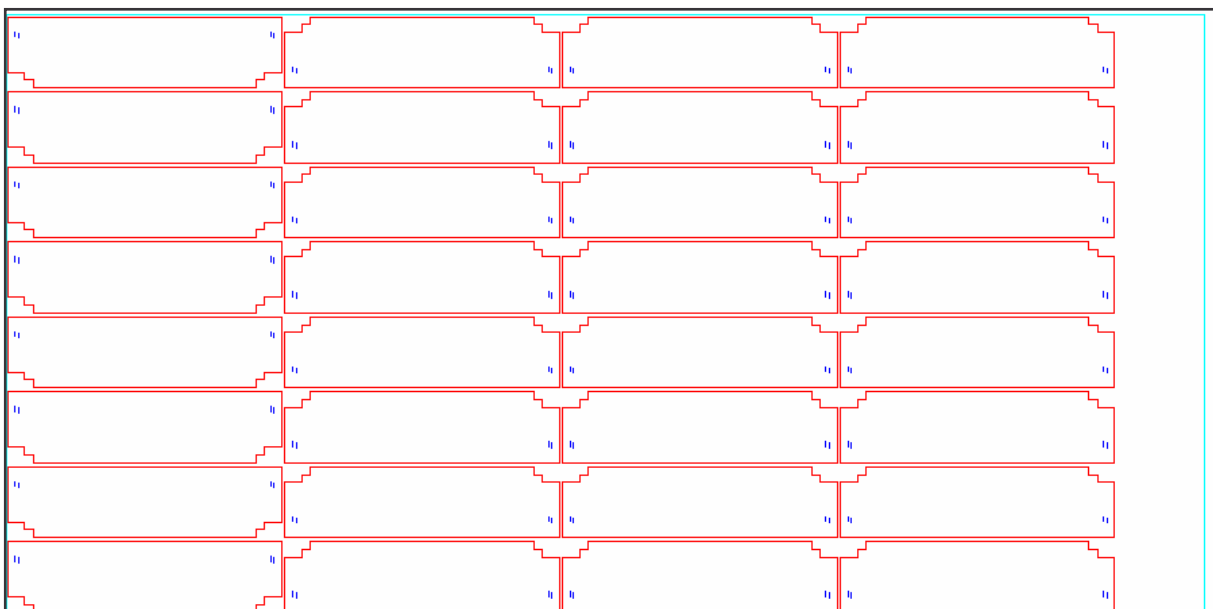

# Combine Cut Logic

## P.E.P. Rotates Parts to Maximize Combine Cutting

The nest below was generated by the **P.E.P. Automatic Nesting software**.

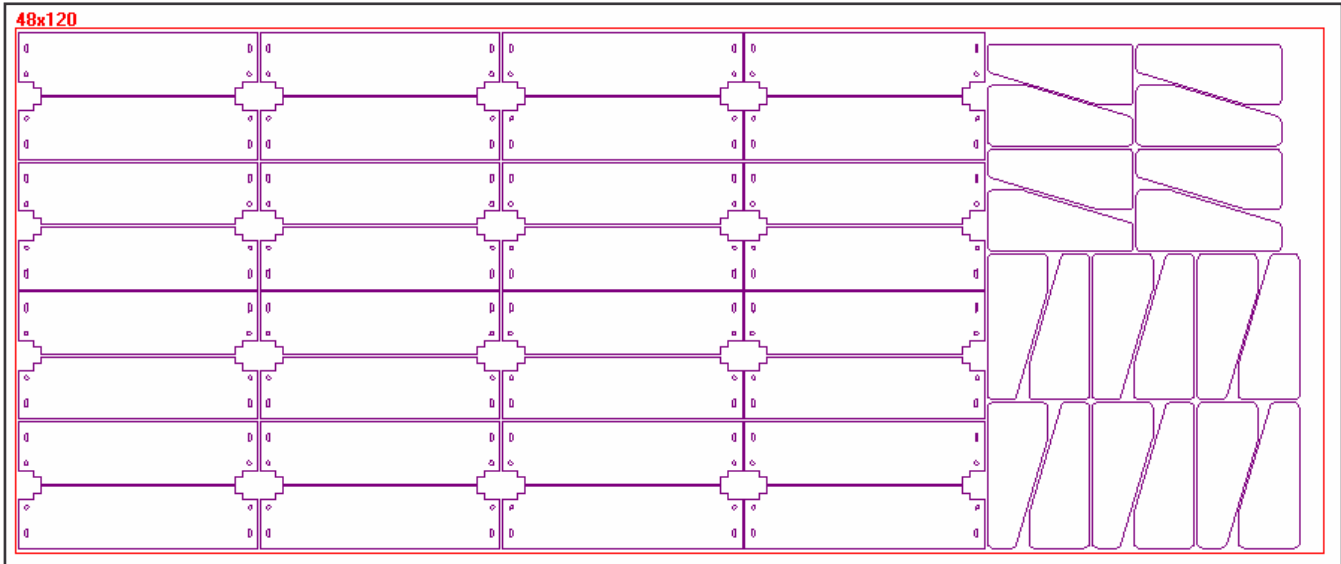

The nest below is typical of the logic used by The Other Approach - **four** parts did not go down

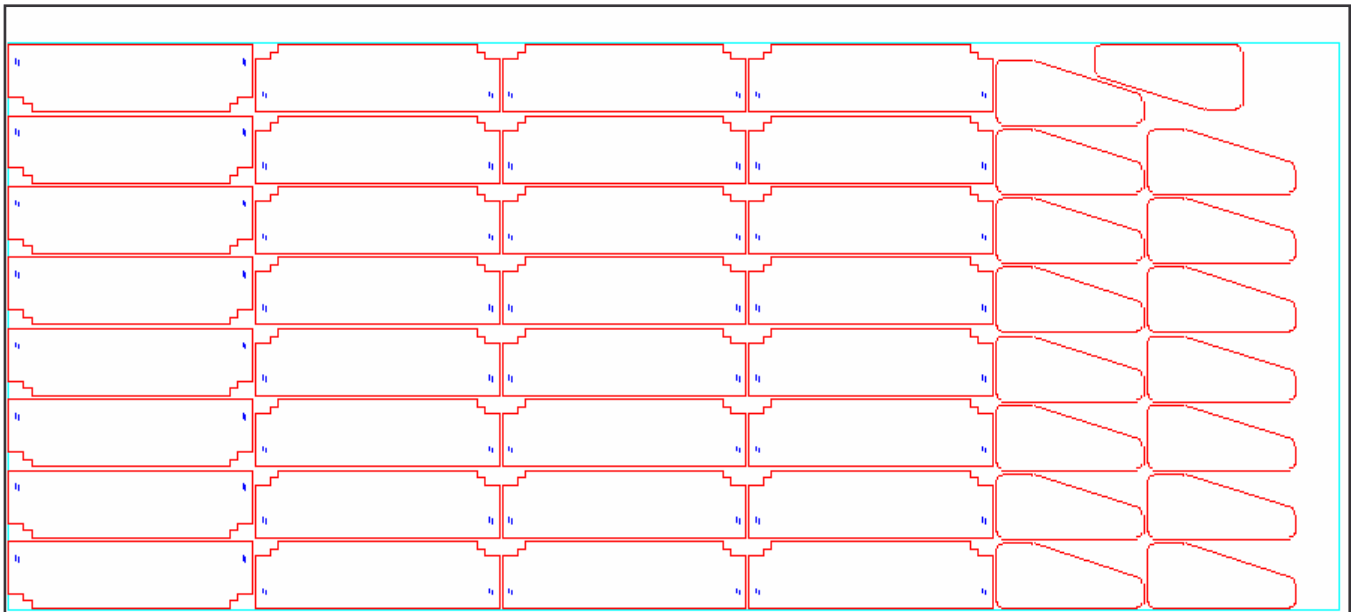

# Combine Cut Logic

## P.E.P. Rotates & Alternates Parts to be Combine Cut

The nest below was generated by the P.E.P. Automatic Nesting software. The parts are rotated and the first part of each row alternated so that the parts can be combine cut.

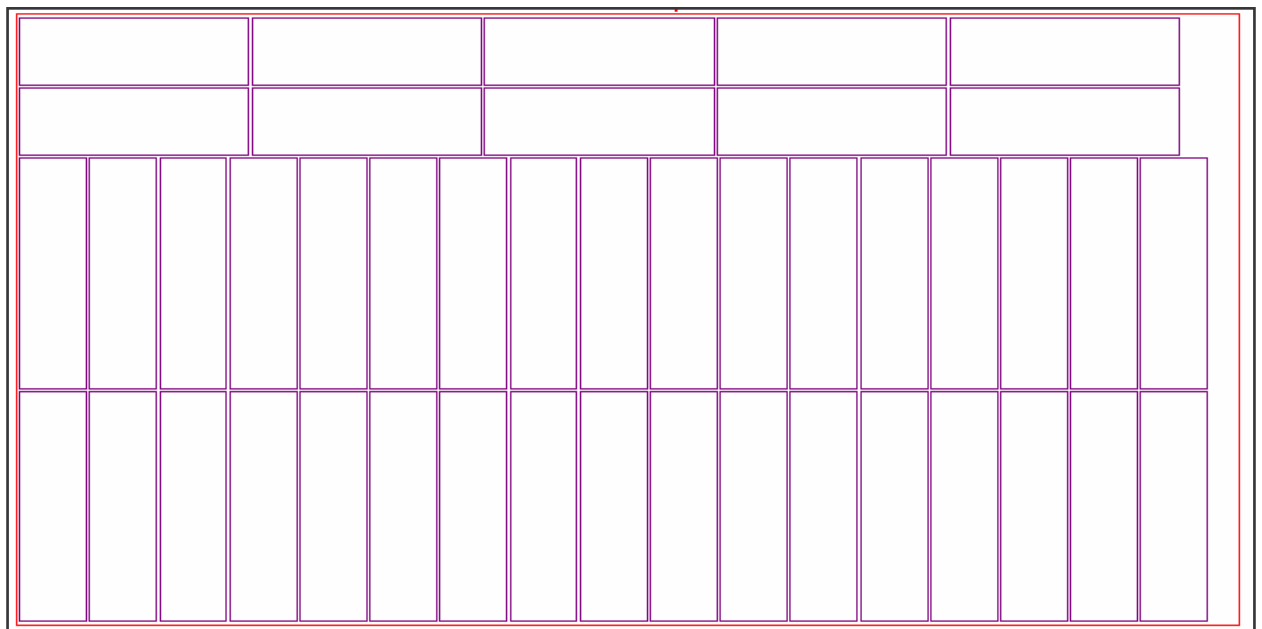
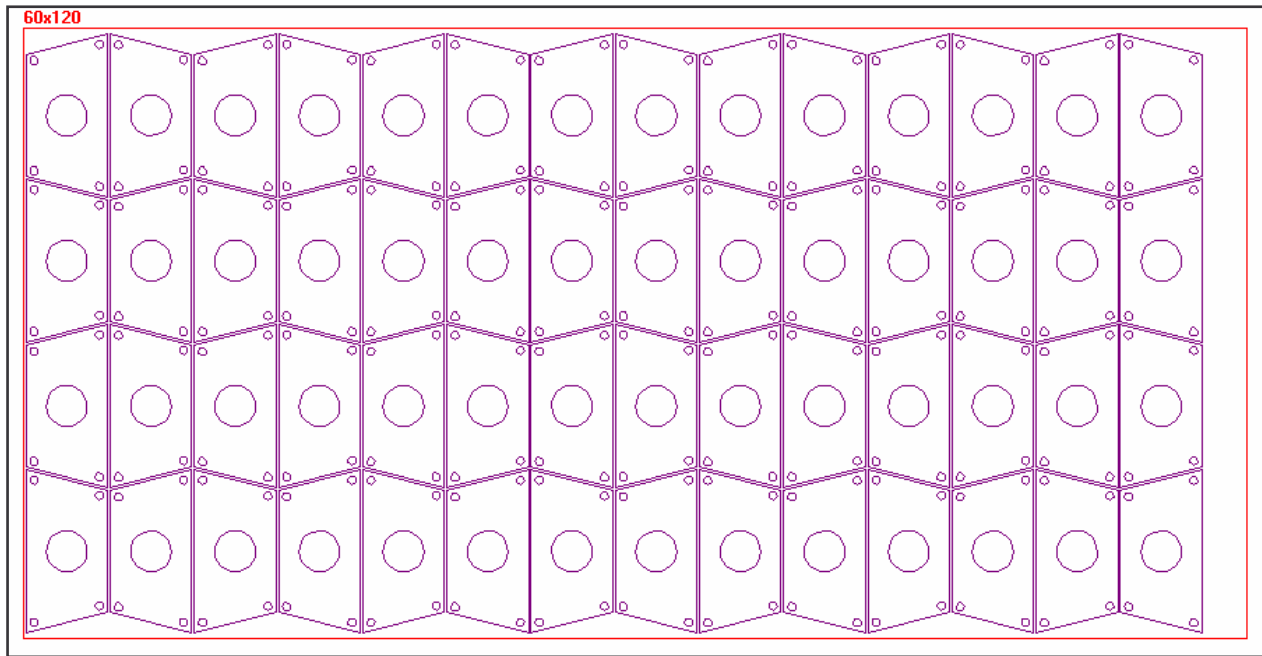

True Rings, one inside of another multiple levels deep.

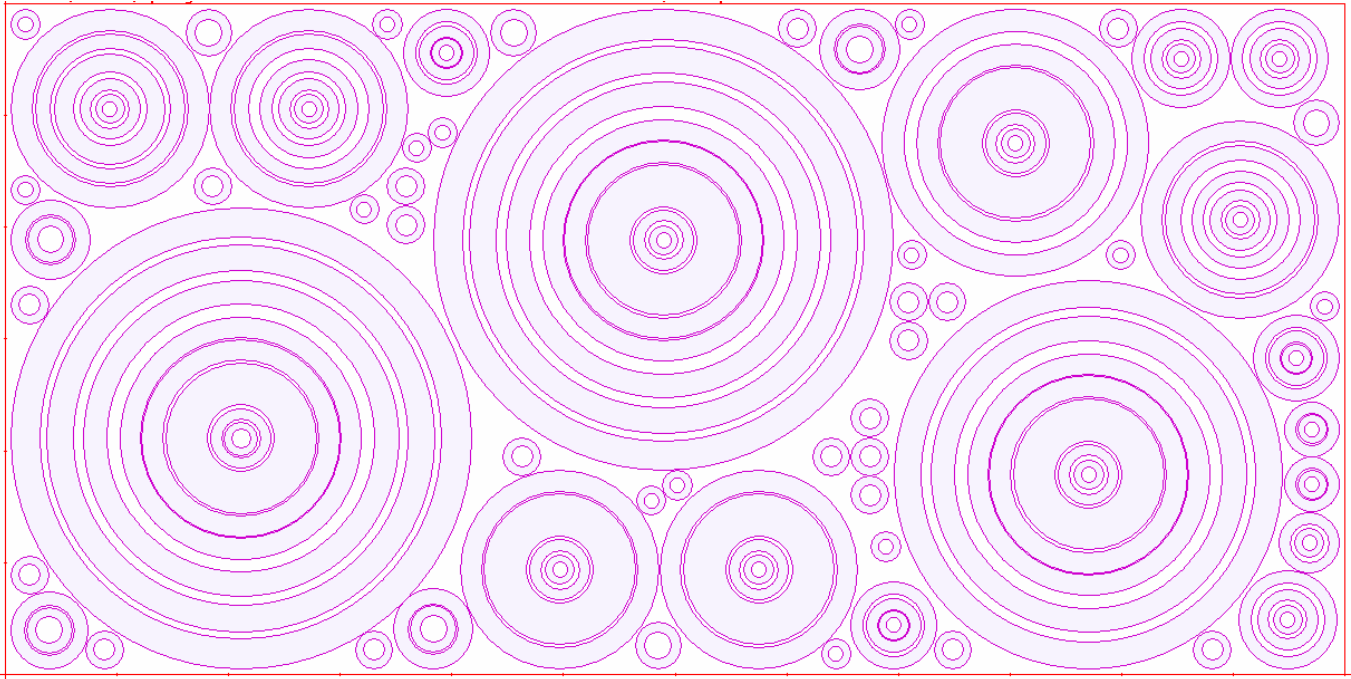

Rings and Circles, one inside of another multiple levels deep.

